

SPECIFICATIONS

Size	Metric	British
Max. Working Height A	22.00m	72ft 2in
Max. Platform Height B	20.00m	65ft 7in
Overall Length C	4.95m	16ft 3in
Overall Width D	2.46m	8ft 1in
Overall Height(Rails Up) E	3.86m	12ft 8in
Overall Height(Rails Down) F	3.00m	9ft 10in
Platform Size(Length×Width)	4.59m×2.25m	15ft 1in × 7ft 5in
Platform Extension Size G	2.70m	8ft 10in
Ground Clearance(Stowed/Raised)	0.40m	1ft 4in
Wheelbase H	3.30m	10ft 10in
Turning Radius(Inside/Outside)	1.25m/3.40m	4ft 1in/11ft 2in
Tyres	36×14-20	36×14-20

Performance		
S.W.L	750kg	1653lb
S.W.L On Extension	750kg	1653lb
Max. Occupants	4	4
Gradeability	30%	30%
Travel Speed(Stowed)	5.0km/h	5.0km/h
Travel Speed(Raised)	0.4km/h	0.4km/h
Max. Working Slope	2°/3°	2°/3°
Up/Down Speed	90/75sec	90/75sec

Weight		
Overall Weight	13400kg	29541lb

Power		
Hydraulic Tank	150L	150L
Battery	48V/630Ah	48V/630Ah
Charger	48V/60A	48V/60A
Driving Motor	4×AC 32V/3.3kW	4×AC 32V/3.3kW
Lifting Motor	2×DC 48V/10.0kW	2×DC 48V/10.0kW

* The platform height plus 2m (7ft in British standard) is the working height.
Standards Compliance

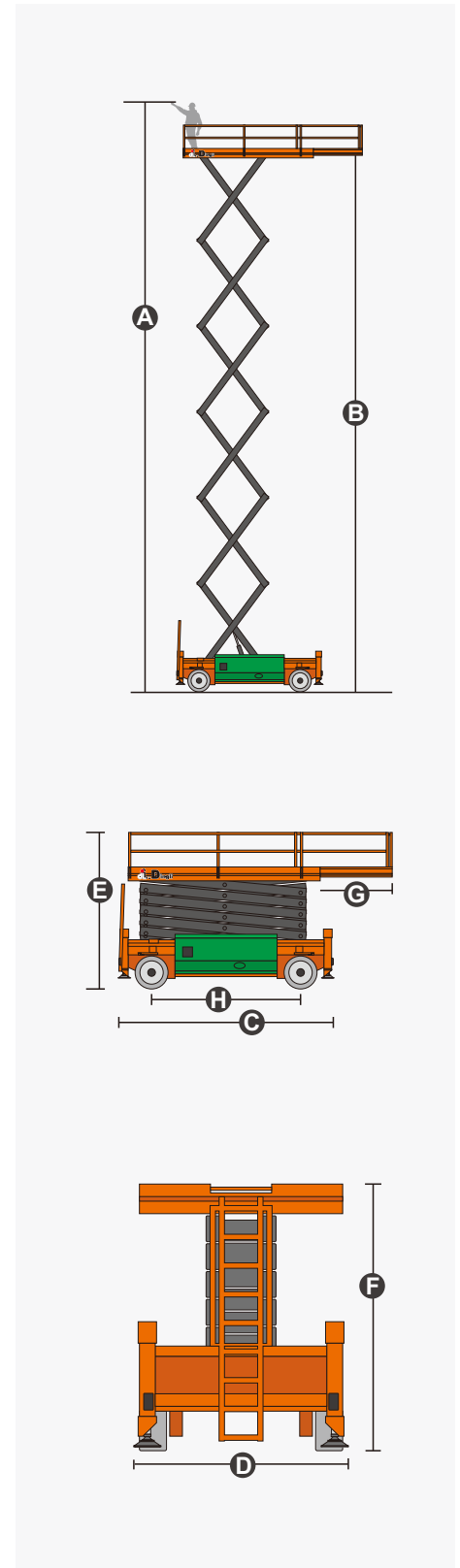

FEATURES

Standard Items

- Proportional Joystick Controls
- Self-Locking Gates
- Charging Indicator
- Drivable At Full Height
- 4×4 Drive
- 4×4 Steer
- Four-Wheel Braking
- Self-Weight Lowering System
- Tubing Explosion-Proof System
- Onboard Fault Diagnostic System
- Tilt Alarm
- Motion Alarm
- Horn
- Hour Meter
- Charging Protection System
- Flashing LED Beacon
- Foldable Guard Rails
- Drive Enable
- Automatic One-Way Platform Extension Deck
- Manual Brake Release
- Lanyard Attachment Point
- Tie-Down And Lifting Points
- Automatic Leveling Hydraulic Outriggers
- Emergency Pump
- Emergency Stop Button
- Platform Load Sense System

Optional Items

Factory Tyres

- Solid Rubber Tyres **
- Non-Marking Tyres

Factory Hydraulic Oil

- No. 46 Hydraulic Oil (Mineral Oil)**

Additional Items

- GPS Unit
- Biodegradable Hydraulic Oil
- AC Power Cord to Platform
- Air Line to Platform
- Work Light Package
- Footpedal Switch
- Anti-Collision Bar on Platform
- Visual Spirit Level
- Outrigger Pad Package
- Guard Mesh Package
- Self-Lubrication System

** Factory Default, If You Have Other Needs, Please Inform Dingli Regional Sales.

ZHEJIANG DINGLI MACHINERY CO., LTD.

No. 188 Qihang Road, Deqing, Zhejiang P.R.China 313219

Telephone +86(572)8681688

Fax +86(572)8681960

E-Mail export@cndingli.com

[Http://www.cndingli.com](http://www.cndingli.com)

