

Genie®



Operator's Manual

with Maintenance Information

Third Edition
Third Printing
Part No. 82594

Z™-34/22

from 3578 to 4684

IC Power

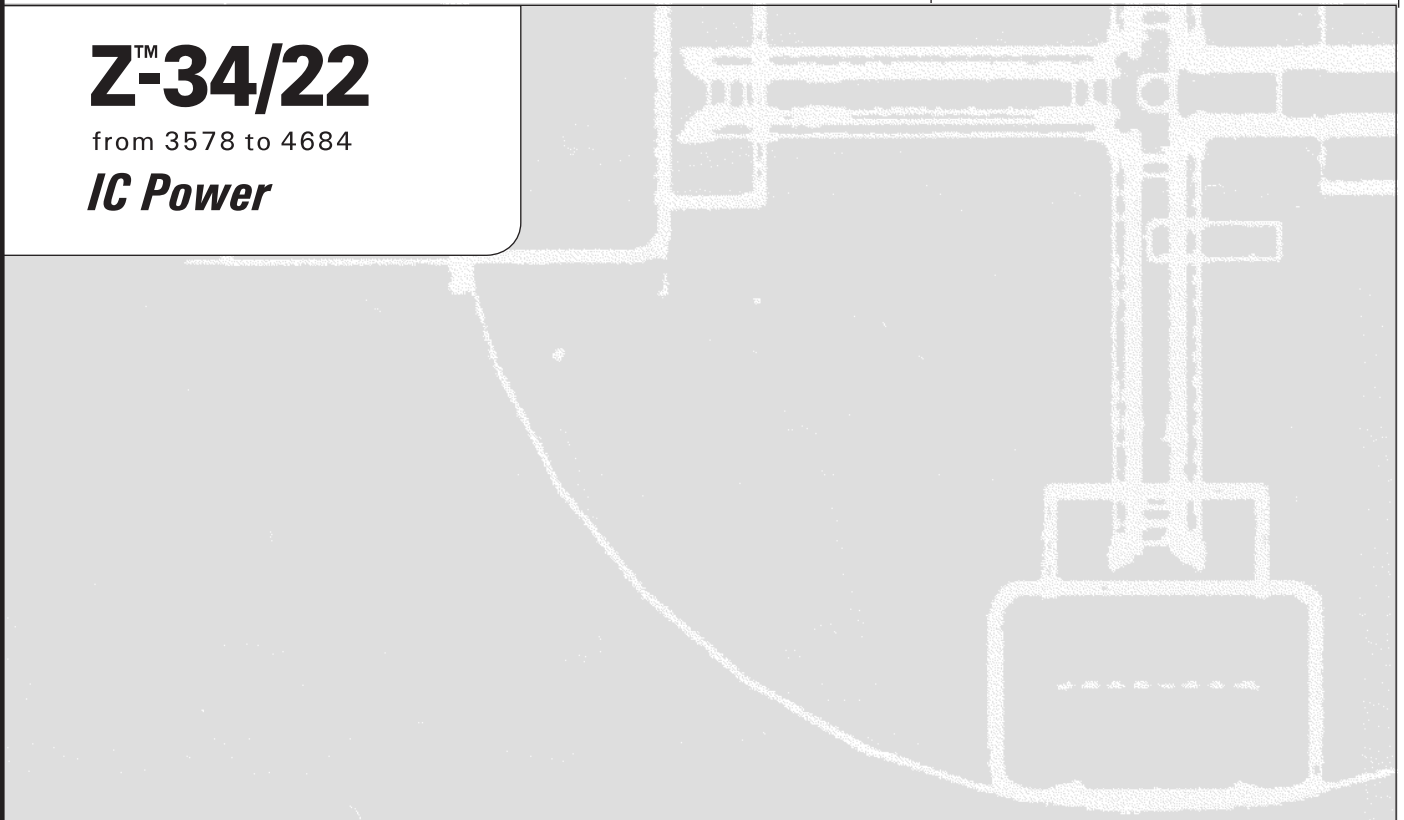

Important

Read, understand and obey these safety rules and operating instructions before operating this machine. Only trained and authorized personnel shall be permitted to operate this machine. This manual should be considered a permanent part of your machine and should remain with the machine at all times. If you have any questions, call Genie Industries.

Contents

	Page
Safety	1
Controls	7
Pre-operation Inspection	9
Maintenance	11
Function Tests	14
Workplace Inspection	19
Operating Instructions	20
Decals	24
Transport and Lifting Instructions	28
Specifications	31

Contact us:

Internet: <http://www.genielift.com>
 e-mail: techpub@genieind.com

Copyright © 1996 by Genie Industries

Third Edition: Third Printing, February 2010

"Genie" and "Z" are registered trademarks of Genie Industries in the U.S.A. and many other countries.

These machines comply with ANSI/SIA 92.5-1992.

 Printed on recycled paper

Printed in U.S.A.

Safety Rules



Danger

Failure to obey the instructions and safety rules in this manual will result in death or serious injury.

Do Not Operate Unless:

- You learn and practice the principles of safe machine operation contained in this operator's manual.
 - 1 Avoid hazardous situations.**
 - Know and understand the safety rules before going on to the next section.**
 - 2 Always perform a pre-operation inspection.
 - 3 Always perform function tests prior to use.
 - 4 Inspect the workplace.
 - 5 Only use the machine as it was intended.
- You read, understand and obey the manufacturer's instructions and safety rules—safety and operator's manuals and machine decals.
- You read, understand and obey employer's safety rules and worksite regulations.
- You read, understand and obey all applicable governmental regulations.
- You are properly trained to safely operate the machine.

SAFETY RULES

Electrocution Hazards

This machine is **not** electrically insulated and will **not** provide protection from contact with or proximity to electrical current.

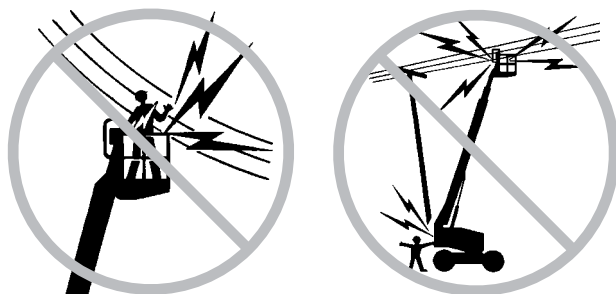

Maintain safe distances from electrical power lines and apparatus in accordance with applicable governmental regulations and the following chart.

Voltage Phase to Phase	Minimum Safe Approach Distance	
	Feet	Meters
0 to 300V	Avoid Contact	
300V to 50KV	10	3.05
50KV to 200KV	15	4.60
200KV to 350KV	20	6.10
350KV to 500KV	25	7.62
500KV to 750KV	35	10.67
750KV to 1000KV	45	13.72

Allow for platform movement, electrical line sway or sag and beware of strong or gusty winds.

Keep away from the machine if it contacts energized power lines. Personnel on the ground or in the platform must not touch or operate the machine until energized power lines are shut off.

Do not operate the machine during lightning or storms.

Do not use the machine as a ground for welding.

Tip-over Hazards

Occupants, equipment and materials shall not exceed the maximum platform capacity.

Maximum platform capacity	500 lbs	227 kg
Maximum occupants	2	

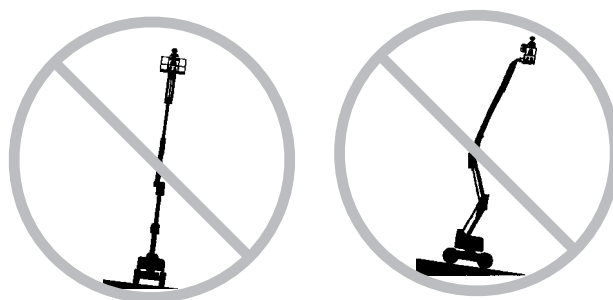

Do not raise or extend the boom unless the machine is on a firm, level surface.

Do not depend on the tilt alarm as a level indicator. The tilt alarm sounds in the platform only when the machine is on a severe slope.

If the tilt alarm sounds:
Do not extend, rotate or raise the boom above horizontal. Move the machine to a firm, level surface before raising the platform. If the tilt alarm sounds when the platform is raised, use extreme caution to retract the boom and lower the platform. Do not rotate the boom while lowering. Move the machine to a firm, level surface before raising the platform.

Do not alter or disable the limit switches.

SAFETY RULES

CE and Australia Markets: Do not use air-filled tires. These machines are equipped with foam-filled tires. Wheel weight and proper counterweight configuration are critical to stability.

Do not drive over 0.6 mph / 1 km/h with the primary boom raised or extended or the secondary boom raised.

Do not operate the machine in strong or gusty winds. Do not increase the surface area of the platform or the load. Increasing the area exposed to the wind will decrease machine stability.

Use extreme care and slow speeds while driving



the machine in stowed position across uneven terrain, debris, unstable or slippery surfaces and near holes and drop-offs.

Do not drive the machine on or near uneven terrain, unstable surfaces or other hazardous conditions with the boom raised or extended.

Do not push off or pull toward any object outside of the platform.

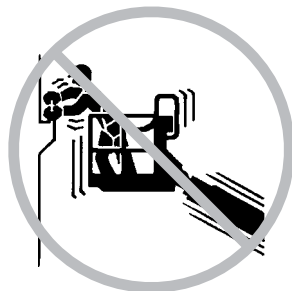

Maximum allowable side force - ANSI & CSA
150 lbs / 667 N

Maximum allowable manual force - CE
90 lbs / 400 N

Do not alter or disable machine components that in any way affect safety and stability.

Do not replace items critical to machine stability with items of different weight or specification.

Do not place or attach overhanging loads to any part of this machine.

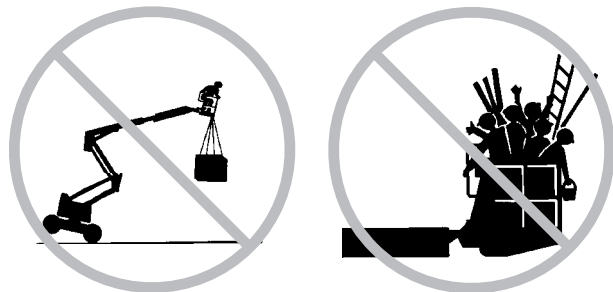

Do not place ladders or scaffolds in the platform or against any part of this machine.

Do not transport tools and materials unless they are evenly distributed and can be safely handled by person(s) in the platform.

Do not use the machine on a moving or mobile surface or vehicle.

Do not modify or alter an aerial work platform without prior written permission from the manufacturer. Mounting attachments for holding tools or other materials onto the platform, toeboards or guard rail system can increase the weight in the platform and the surface area of the platform or the load.

SAFETY RULES

Be sure all tires are in good condition and the lug nuts are properly tightened.

Do not use the machine as a crane.

Do not push the machine or other objects with the boom.

Do not contact adjacent structures with the boom.

Do not tie the boom or platform to adjacent structures.

Do not place loads outside the platform perimeter.

Fall Hazards

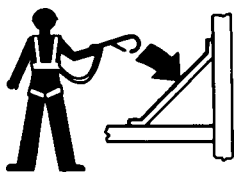

Occupants must wear a safety belt or harness and comply with applicable governmental regulations. Attach the lanyard to the anchor provided in the platform.

Do not sit, stand or climb on the platform guard rails. Maintain a firm footing on the platform floor at all times.

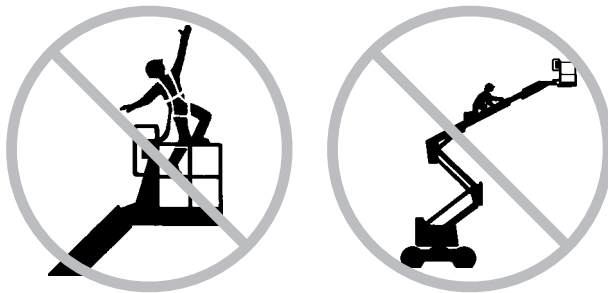

Do not climb down from the platform when raised.

Keep the platform floor clear of debris.

Lower the platform entry mid-rail or close the entry gate before operating.

Collision Hazards

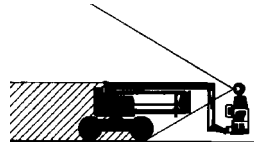

Be aware of limited sight distance and blind spots when driving or operating.

Be aware of the boom position when rotating the turntable.

Check the work area for overhead obstructions or other possible hazards.

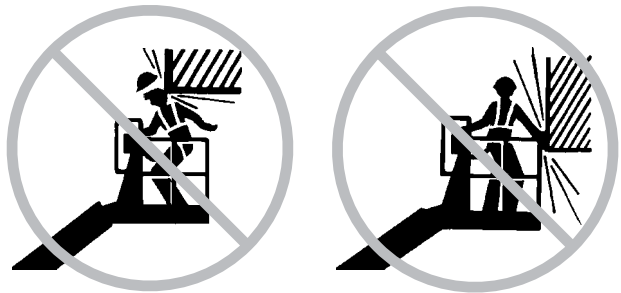

Be aware of crushing hazards when grasping the platform guard rail.

Operators must comply with employer, job site and governmental rules regarding the use of personal protective equipment.

Observe and use color-coded direction arrows on the platform controls and drive chassis for drive and steer functions.

SAFETY RULES

Do not lower the boom unless the area below is clear of personnel and obstructions.



Limit travel speed according to the condition of the ground surface, congestion, slope, location of personnel, and any other factors which may cause collision.

Do not operate a boom in the path of any crane unless the controls of the crane have been locked out and/or precautions have been taken to prevent any potential collision.

No stunt driving or horseplay while operating a machine.

Component Damage Hazard

Do not use any battery or charger greater than 12V to jump-start the engine.

Do not use the machine as a ground for welding.

Explosion and Fire Hazards

Do not start the engine if you smell or detect liquid petroleum gas (LPG), gasoline, diesel fuel or other explosive substances.

Do not refuel the machine with the engine running.

Refuel the machine and charge the battery only in an open, well-ventilated area away from sparks, flames and lighted tobacco.

Damaged Machine Hazards

Do not use a damaged or malfunctioning machine.

Conduct a thorough pre-operation inspection of the machine and test all functions before each work shift. Immediately tag and remove from service a damaged or malfunctioning machine.

Be sure all maintenance has been performed as specified in this manual and the appropriate service manual.

Be sure all decals are in place and legible.

Be sure the operator's, safety and responsibilities manuals are complete, legible and in the storage container located on the platform.

SAFETY RULES

Bodily Injury Hazard

Do not operate the machine with a hydraulic oil or air leak. An air leak or hydraulic leak can penetrate and/or burn skin.

Always operate the machine in a well-ventilated area to avoid carbon monoxide poisoning.

Improper contact with components under any cover will cause serious injury. Only trained maintenance personnel should access compartments. Access by the operator is only advised when performing a pre-operation inspection. All compartments must remain closed and secured during operation.

Battery Safety**Burn Hazards**

Batteries contain acid. Always wear protective clothing and eyewear when working with batteries.

Avoid spilling or contacting battery acid. Neutralize battery acid spills with baking soda and water.

Explosion Hazard

Keep sparks, flames and lighted tobacco away from batteries. Batteries emit explosive gas.

Electrocution Hazard

Avoid contact with electrical terminals.

Decal Legend

Genie product decals use symbols, color coding and signal words to identify the following:



Safety alert symbol—used to alert personnel to potential personal injury hazards. Obey all safety messages that follow this symbol to avoid possible injury or death.



Red—used to indicate the presence of an imminently hazardous situation which, if not avoided, will result in death or serious injury.



Orange—used to indicate the presence of a potentially hazardous situation which, if not avoided, could result in death or serious injury.



Yellow with safety alert symbol—used to indicate the presence of a potentially hazardous situation which, if not avoided, may cause minor or moderate injury.



Yellow without safety alert symbol—used to indicate the presence of a potentially hazardous situation which, if not avoided, may result in property damage.



Green—used to indicate operation or maintenance information.

Controls

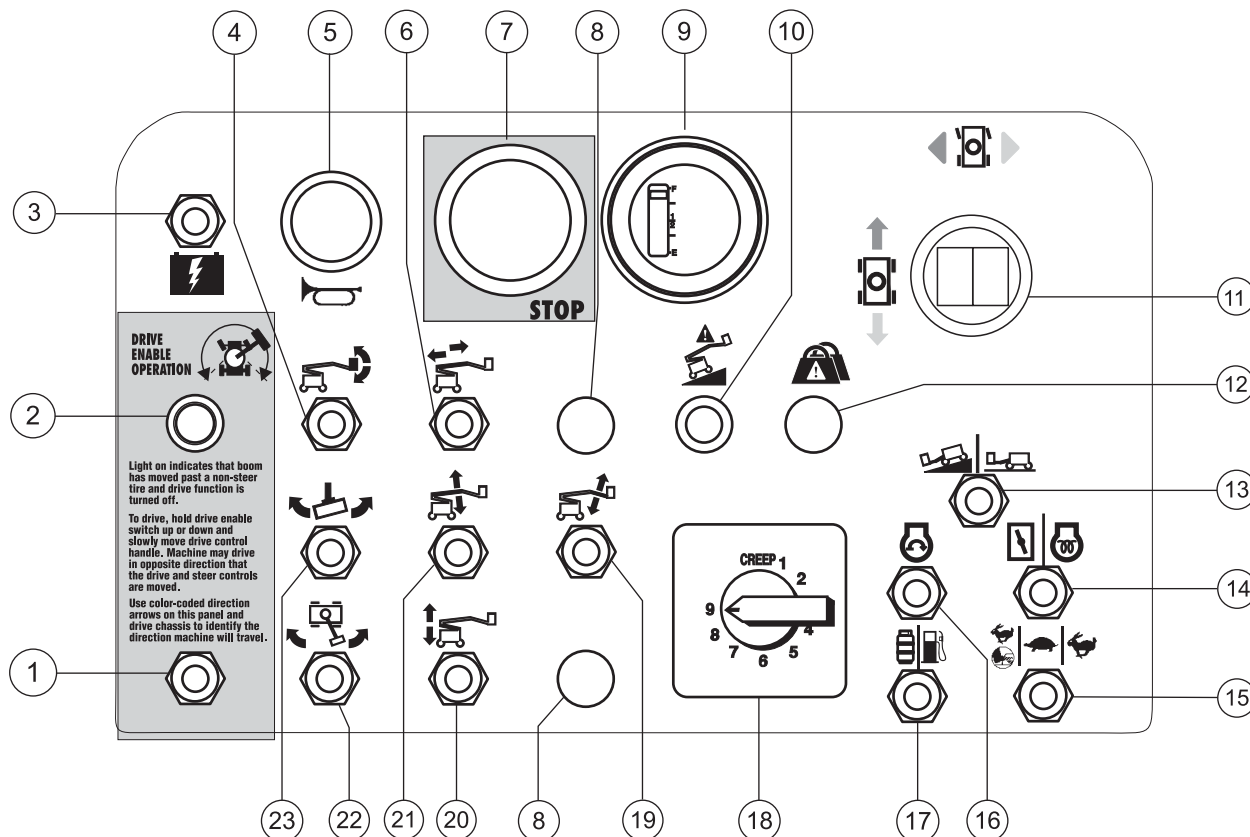

Platform Control Panel

- | | | |
|----------------------------------------------------------------------------------------------------------------------------------------------------------------------------------------------------------------------------------------------------------------------------------------------------|----------------------------------------------------------------------------------------------------------------------------------------------------------------------------------------------------------------------------------------------------------------------------------------------------------------------------------------------------------------------------------------------------------------------------------------------------------------------------------------------------------------------------------------------------------------|---------------------------------------------------------------------------------------------------------------------------------------------------------------------------------------------------------------------------------------------------------------------------------------------------------------------|
| <p>1 Drive enable switch</p> <p>2 Drive enable indicator light</p> <p>3 Auxiliary power switch</p> <p>4 Platform level switch</p> <p>5 Horn button</p> <p>6 Primary boom extend/retract switch</p> <p>7 Red Emergency Stop button</p> <p>8 Not used</p> <p>9 Battery charge indicator (option)</p> | <p>10 Machine not level indicator light (if equipped)</p> <p>11 Proportional control handle for drive function and thumb rocker for steer function</p> <p>12 Platform overload indicator light (if equipped)</p> <p>13 Drive speed select switch</p> <p>14 Gasoline/LPG models: Choke switch
Diesel models: Glow plug switch (option)</p> <p>15 Engine idle (rpm) select switch</p> <ul style="list-style-type: none"> • Rabbit & foot switch: foot switch activated high idle • Turtle: low idle • Rabbit: high idle | <p>16 Engine start switch</p> <p>17 Gasoline/LPG models: Gasoline/LPG select switch</p> <p>18 Boom function speed controller</p> <p>19 Jib boom up/down switch</p> <p>20 Secondary boom up/down switch</p> <p>21 Primary boom up/down switch</p> <p>22 Turntable rotate switch</p> <p>23 Platform rotate switch</p> |
|----------------------------------------------------------------------------------------------------------------------------------------------------------------------------------------------------------------------------------------------------------------------------------------------------|----------------------------------------------------------------------------------------------------------------------------------------------------------------------------------------------------------------------------------------------------------------------------------------------------------------------------------------------------------------------------------------------------------------------------------------------------------------------------------------------------------------------------------------------------------------|---------------------------------------------------------------------------------------------------------------------------------------------------------------------------------------------------------------------------------------------------------------------------------------------------------------------|

CONTROLS

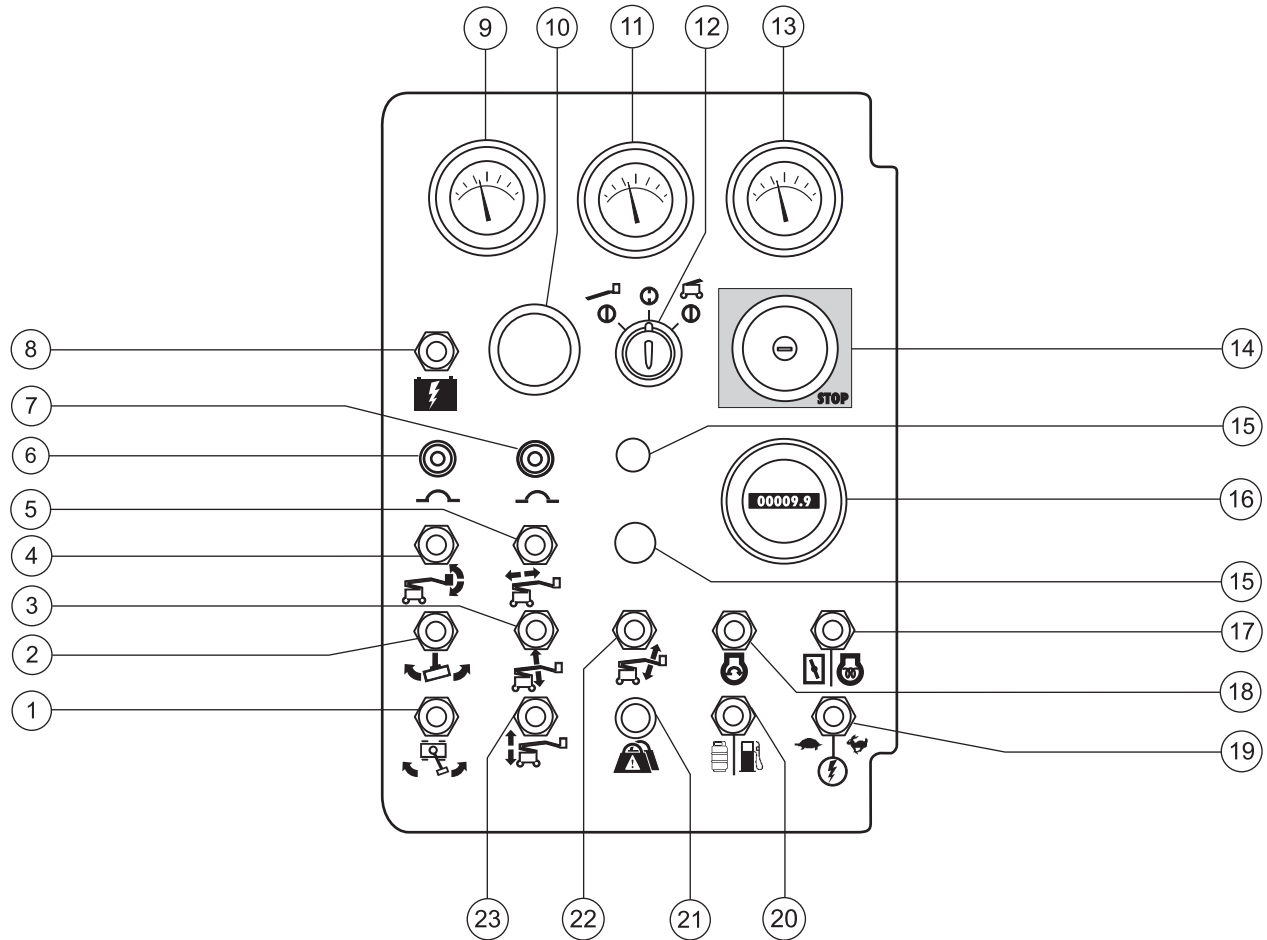

Ground Control Panel

- | | | |
|---------------------------------------------------------------------------------------------------------------------------------------------------------------------------------------------------------------------------------------------------------------------------------------------------------------------------|---------------------------------------------------------------------------------------------------------------------------------------------------------------------------------------------------------------------------------------------------------------------------------------------------------------|----------------------------------------------------------------------------------------------------------------------------------------------------------------------------------------------------------------------------------------------------------------------------------------------------------------------------------------------------|
| <p>1 Turntable rotate switch</p> <p>2 Platform rotate switch</p> <p>3 Primary boom up/down switch</p> <p>4 Platform level switch</p> <p>5 Primary boom extend/retract switch</p> <p>6 10A breaker for engine electrical circuits</p> <p>7 10A breaker for control electrical circuits</p> <p>8 Auxiliary power switch</p> | <p>9 Gasoline/LPG models: Water temperature gauge
Diesel models: Oil temperature gauge</p> <p>10 Travel alarm</p> <p>11 Oil pressure gauge</p> <p>12 Key switch for platform/off/ground selection</p> <p>13 Voltage gauge</p> <p>14 Red Emergency Stop button</p> <p>15 Not used</p> <p>16 Hour meter</p> | <p>17 Gasoline/LPG models: Choke switch
Diesel models: Glow plug switch (option)</p> <p>18 Engine start switch</p> <p>19 Function enable switch</p> <p>20 Gasoline/LPG models: Fuel select switch</p> <p>21 Platform overload indicator light (if equipped)</p> <p>22 Jib boom up/down switch</p> <p>23 Primary boom extend/retract switch</p> |
|---------------------------------------------------------------------------------------------------------------------------------------------------------------------------------------------------------------------------------------------------------------------------------------------------------------------------|---------------------------------------------------------------------------------------------------------------------------------------------------------------------------------------------------------------------------------------------------------------------------------------------------------------|----------------------------------------------------------------------------------------------------------------------------------------------------------------------------------------------------------------------------------------------------------------------------------------------------------------------------------------------------|

Pre-operation Inspection



Do Not Operate Unless:

- You learn and practice the principles of safe machine operation contained in this operator's manual.

1 Avoid hazardous situations.

2 Always perform a pre-operation inspection.

Know and understand the pre-operation inspection before going on to the next section.

3 Always perform function tests prior to use.

4 Inspect the workplace.

5 Only use the machine as it was intended.

Fundamentals

It is the responsibility of the operator to perform a pre-operation inspection and routine maintenance.

The pre-operation inspection is a visual inspection performed by the operator prior to each work shift. The inspection is designed to discover if anything is apparently wrong with a machine before the operator performs the function tests.

The pre-operation inspection also serves to determine if routine maintenance procedures are required. Only routine maintenance items specified in this manual may be performed by the operator.

Refer to the list on the next page and check each of the items.

If damage or any unauthorized variation from factory delivered condition is discovered, the machine must be tagged and removed from service.

Repairs to the machine may only be made by a qualified service technician, according to the manufacturer's specifications. After repairs are completed, the operator must perform a pre-operation inspection again before going on to the function tests.

Scheduled maintenance inspections shall be performed by qualified service technicians, according to the manufacturer's specifications and the requirements listed in the responsibilities manual.

PRE-OPERATION INSPECTION

Pre-operation Inspection

- Be sure that the operator's, safety and responsibilities manuals are complete, legible and in the storage container located on the platform.
 - Be sure that all decals are legible and in place. See Decals section.
 - Check for engine oil leaks and proper fluid level. Add oil if needed. See Maintenance section.
 - Check for engine coolant leaks and proper fluid level. Add coolant if needed. See Maintenance section.
 - Check for hydraulic oil leaks and proper oil level. Add oil if needed. See Maintenance section.
 - Check for battery fluid leaks and proper fluid level. Add distilled water if needed. See Maintenance section.
 - Check for proper tire pressure. Add air if needed. See Maintenance section.
 - Platform entry mid-rail/gate
 - Beacon and alarms (if equipped)
- Check entire machine for:
- Cracks in welds or structural components
 - Dents or damage to machine
 - Be sure that all structural and other critical components are present and all associated fasteners and pins are in place and properly tightened.
 - After you complete your inspection, be sure that all compartment covers are in place and latched.

Check the following components or areas for damage, improperly installed or missing parts and unauthorized modifications:

- Electrical components, wiring and electrical cables
- Hydraulic power unit, reservoir, hoses, fittings, cylinders and manifolds
- Generator, belts and related components
- Fuel and hydraulic tanks
- Drive and turntable motors and torque hubs
- Boom wear pads
- Tires and wheels
- Engine and related components
- Limit switches, alarms and horn
- Nuts, bolts and other fasteners

Maintenance



Observe and Obey:

- ☑ Only routine maintenance items specified in this manual shall be performed by the operator.
- ☑ Scheduled maintenance inspections shall be completed by qualified service technicians, according to the manufacturer's specifications and the requirements specified in the responsibilities manual.

Maintenance Symbols Legend

NOTICE

The following symbols have been used in this manual to help communicate the intent of the instructions. When one or more of the symbols appear at the beginning of a maintenance procedure, it conveys the meaning below.



Indicates that tools will be required to perform this procedure.



Indicates that new parts will be required to perform this procedure.

Check the Hydraulic Oil Level



Maintaining the hydraulic oil at the proper level is essential to machine operation. Improper hydraulic oil levels can damage hydraulic components. Daily checks allow the inspector to identify changes in oil level that might indicate the presence of hydraulic system problems.

- 1 Be sure the boom is in the stowed position.
- 2 Visually inspect the site gauge located on the side of the hydraulic tank.
- ⦿ Result: The hydraulic oil level should be within the FULL and ADD marks on the hydraulic tank.
- 3 Add oil if necessary.

Hydraulic oil specifications

Hydraulic oil type	Chevron Rykon Premium MV equivalent
--------------------	----------------------------------------

Check the Engine Coolant Level



Maintaining the engine coolant at the proper level is essential to engine service life. Improper coolant level will affect the engine's cooling capability and damage engine components. Daily checks will allow the inspector to identify changes in coolant level that might indicate cooling system problems.

- 1 Check the fluid level in the coolant recovery tank.
- ⦿ Result: The fluid level should be in the NORMAL range.
- 2 Add fluid if necessary.

MAINTENANCE

Check the Engine Oil Level



Maintaining the proper engine oil level is essential to good engine performance and service life. Operating the machine with an improper oil level can damage engine components.

NOTICE Check the oil level with the engine off.

- 1 Check the oil level dipstick.
- ⦿ **Result:** The oil level should be at the FULL mark on the dipstick.
- 2 Add oil if necessary.

Kubota Engine DF-750

Oil viscosity requirements	10W-30
----------------------------	--------

Use oils meeting API classification SF (labeled SF/CC or SF/CD) for improved wear protection.
Units ship with 10W-40 SG/CC

Kubota Engine D-905 B-22

Oil viscosity requirements	10W-30
----------------------------	--------

Engine oil should have properties of API classification CC/SE, CD/SE, CC/SF grades.
Units ship with 10W-40 SG/CC

Check the Batteries



Proper battery condition is essential to good engine performance and operational safety. Improper fluid levels or damaged cables and connections can result in engine component damage and hazardous conditions.

WARNING Bodily injury hazard. Batteries contain acid. Avoid spilling or contacting battery acid. Neutralize battery acid spills with baking soda and water.

- 1 Put on protective clothing and eye wear.
- 2 Be sure that the battery cable connections are tight and free of corrosion.
- 3 Be sure that the battery hold-down bracket is tight.
- 4 Remove the battery vent caps.
- 5 Check the battery acid level. If needed, replenish with distilled water to the bottom of the battery fill tube. Do not overfill.
- 6 Install the vent caps.

MAINTENANCE

Check the Tire Pressure



NOTICE This procedure does not need to be performed on machines equipped with the foam-filled tire option.

AWARNING Bodily injury hazard. An over-inflated tire can explode and may cause death or serious injury.

AWARNING Tip-over hazard. Do not use temporary flat tire repair products.

To safeguard maximum stability, achieve optimum machine handling and minimize tire wear, it is essential to maintain proper pressure in all air-filled tires.

- 1 Check each tire with an air pressure gauge and add air as needed.

Tire pressure

Industrial tire	100 psi	6.89 bar
Rough terrain tire	45 psi	3.1 bar

Scheduled Maintenance

Maintenance performed quarterly, annually and every two years must be completed by a person trained and qualified to perform maintenance on this machine according to the procedures found in the service manual for this machine.

Machines that have been out of service for more than three months must receive the quarterly inspection before they are put back into service.

Function Tests



Do Not Operate Unless:

- You learn and practice the principles of safe machine operation contained in this operator's manual.

- 1 Avoid hazardous situations.
- 2 Always perform a pre-operation inspection.

3 Always perform function tests prior to use.

Know and understand the function tests before going on to the next section.

- 4 Inspect the workplace.
- 5 Only use the machine as it was intended.

Fundamentals

The function tests are designed to discover any malfunctions before the machine is put into service. The operator must follow the step-by-step instructions to test all machine functions.

A malfunctioning machine must never be used. If malfunctions are discovered, the machine must be tagged and removed from service. Repairs to the machine may only be made by a qualified service technician, according to the manufacturer's specifications.

After repairs are completed, the operator must perform a pre-operation inspection and function tests again before putting the machine into service.

FUNCTION TESTS

- 1 Select a test area that is firm, level and free of obstruction.

At the Ground Controls

- 2 Turn the key switch to ground control.
- 3 Pull out the red Emergency Stop button to the on position.
- ⦿ Result: The beacon (if equipped) should flash.
- 4 Start the engine. See Operating Instructions section.

Test the Emergency Stop

- 5 Push in the red Emergency Stop button to the off position.
- ⦿ Result: The engine should turn off and all functions should not operate.
- 6 Pull out the red Emergency Stop button to the on position and restart the engine.

Test the Machine Functions

- 7 Do not hold the function enable switch to either side. Attempt to activate each boom and platform function toggle switch. 
- ⦿ Result: All boom and platform functions should not operate.
- 8 Hold the function enable switch to either side and activate each boom and platform function toggle switch.
- ⦿ Result: All boom and platform functions should operate through a full cycle. The descent alarm (if equipped) should sound while the boom is lowering.

Machines equipped with Platform Level Control Disable Function: The platform level toggle switch will not operate when the primary boom is raised past the drive speed limit switch.

Test the Tilt Sensor

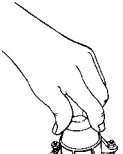
- 9 Pull out the platform red Emergency Stop button to the on position. Turn the key switch to platform control.
- 10 Open the ground control side turntable cover and locate the tilt sensor.
- 11 Press down one side of the tilt sensor. 
- ⦿ Result: The alarm, located in the platform, should sound.

Test Auxiliary Controls

- 12 Turn the key switch to ground control and shut the engine off.
- 13 Pull out the red Emergency Stop button to the on position.
- 14 Simultaneously hold the auxiliary power switch on and activate each boom function toggle switch. 

Note: To conserve battery power, test each function through a partial cycle.

- ⦿ Result: All boom functions should operate.

FUNCTION TESTS

At the Platform Controls**Test the Emergency Stop**

15 Turn the key switch to platform control and restart the engine.

16 Push in the platform red Emergency Stop button to the off position.

⦿ Result: The engine should turn off and all functions should not operate.

17 Pull out the red Emergency Stop button and restart the engine.

Test the Horn

18 Push the horn button.

⦿ Result: The horn should sound.

Test the Foot Switch

19 Push in the platform red Emergency Stop button to the off position.

20 Pull out the red Emergency Stop button to the on position but do not start the engine.

21 Press down the foot switch and attempt to start the engine by moving the start toggle switch to either side.

⦿ Result: The engine should not start.

22 Do not press down the foot switch and start the engine.

23 Do not press down the foot switch. Test each machine function.

⦿ Result: The machine functions should not operate.

Test Machine Functions

24 Press down the foot switch.

25 Activate each machine function control handle or toggle switch.

⦿ Result: All boom and platform functions should operate through a full cycle.

Note: Control the speed of boom functions by adjusting the boom function speed controller. Drive and steer functions are not affected by the boom function speed controller.

Machines equipped with Platform Level Control Disable Function: The platform level toggle switch will not operate when the primary boom is raised past the drive speed limit switch.

Test the Steering

26 Press down the foot switch.

27 Depress the thumb rocker switch on top of the drive control handle in the direction identified by the blue triangle on the control panel.

⦿ Result: The steer wheels should turn in the direction that the blue triangles point on the drive chassis.

28 Depress the thumb rocker switch in the direction identified by the yellow triangle on the control panel.

⦿ Result: The steer wheels should turn in the direction that the yellow triangles point on the drive chassis.

FUNCTION TESTS

Test Drive and Braking

29 Press down the foot switch.

30 Slowly move the drive control handle in the direction indicated by the blue arrow on the control panel until the machine begins to move, then return the handle to the center position.

- ⦿ Result: The travel alarm should sound. The machine should move in the direction that the blue arrow points on the drive chassis, then come to an abrupt stop.

31 Slowly move the drive control handle in the direction indicated by the yellow arrow on the control panel until the machine begins to move, then return the handle to the center position.

- ⦿ Result: The travel alarm should sound. The machine should move in the direction that the yellow arrow points on the drive chassis, then come to an abrupt stop.

Note: The brakes must be able to hold the machine on any slope it is able to climb.

Test the Drive Enable System

32 Press down the foot switch.

33 Retract the primary boom to the stowed position.

34 Rotate the turntable until the boom moves past one of the non-steer wheels.

- ⦿ Result: The drive enable indicator light should come on and remain on while the boom is anywhere in the range shown.

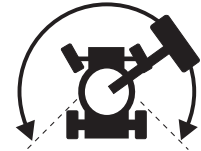

35 Move the drive control handle off center.

- ⦿ Result: The drive function should not operate.

36 Move and hold the drive enable toggle switch up or down and slowly move the drive control handle off center.

- ⦿ Result: The drive function should operate.

Note: When the drive enable system is in use, the machine may drive in the opposite direction that the drive and steer control handle is moved.

Use the color-coded direction arrows on the platform controls and the drive chassis to identify the direction of travel.

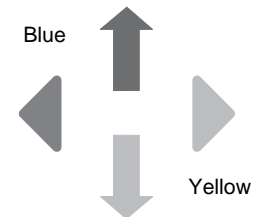

FUNCTION TESTS

Test Limited Drive Speed

- 37 Press down the foot switch.
- 38 Raise the primary boom 1 foot / 30 cm.
- 39 Slowly move the drive control handle to the full drive position.
- ⦿ Result: The maximum achievable drive speed with the primary boom raised should not exceed 1 foot / 30 cm per second.
- 40 Lower the boom to the stowed position.
- 41 Raise the secondary boom 1 foot / 30 cm.
- 42 Slowly move the drive control handle to the full drive position.
- ⦿ Result: The maximum achievable drive speed with the secondary boom raised should not exceed 1 foot / 30 cm per second.
- 43 Lower the boom to the stowed position.
- 44 Extend the primary boom 1 foot / 30 cm.
- 45 Slowly move the drive control handle to the full drive position.
- ⦿ Result: The maximum achievable drive speed with the primary boom extended should not exceed 1 foot / 30 cm per second.

If the drive speed with the primary boom raised or extended or the secondary boom raised exceeds 1 foot / 30 cm per second, immediately tag and remove the machine from service.

Test Auxiliary Controls

- 46 Shut off the engine.
- 47 Pull out the red Emergency Stop button to the on position.
- 48 Press down the foot switch.
- 49 Simultaneously hold the auxiliary power switch on and activate each function control handle or toggle switch.

Note: To conserve battery power, test each function through a partial cycle.

- ⦿ Result: All boom and steer functions should operate. Drive function should not operate with auxiliary power.

Test the Lift/Drive Select Function (if equipped)

- 50 Press down the foot switch.
- 51 Move the drive control handle off center and activate a boom function toggle switch.
- ⦿ Result: No boom functions should operate. The machine will move in the direction indicated on the control panel.

Workplace Inspection



Do Not Operate Unless:

- You learn and practice the principles of safe machine operation contained in this operator's manual.

- 1 Avoid hazardous situations.
- 2 Always perform a pre-operation inspection.
- 3 Always perform function tests prior to use.

4 Inspect the workplace.

Know and understand the workplace inspection before going on to the next section.

- 5 Only use the machine as it was intended.

Workplace Inspection

Be aware of and avoid the following hazardous situations:

- drop-offs or holes
- bumps, floor obstructions or debris
- sloped surfaces
- unstable or slippery surfaces
- overhead obstructions and high voltage conductors
- hazardous locations
- inadequate surface support to withstand all load forces imposed by the machine
- wind and weather conditions
- the presence of unauthorized personnel
- other possible unsafe conditions

Fundamentals

The workplace inspection helps the operator determine if the workplace is suitable for safe machine operation. It should be performed by the operator prior to moving the machine to the workplace.

It is the operator's responsibility to read and remember the workplace hazards, then watch for and avoid them while moving, setting up and operating the machine.

Operating Instructions



Do Not Operate Unless:

- You learn and practice the principles of safe machine operation contained in this operator's manual.
 - 1 Avoid hazardous situations.
 - 2 Always perform a pre-operation inspection.
 - 3 Always perform function tests prior to use.
 - 4 Inspect the workplace.
 - 5 Only use the machine as it was intended.**

Fundamentals

The Operating Instructions section provides instructions for each aspect of machine operation. It is the operator's responsibility to follow all the safety rules and instructions in the operator's, safety and responsibilities manuals.

Using the machine for anything other than lifting personnel, along with their tools and materials, to an aerial work site is unsafe and dangerous.

Only trained and authorized personnel should be permitted to operate a machine. If more than one operator is expected to use a machine at different times in the same work shift, they must all be qualified operators and are all expected to follow all safety rules and instructions in the operator's, safety and responsibilities manuals. That means every new operator should perform a pre-operation inspection, function tests, and a workplace inspection before using the machine.

OPERATING INSTRUCTIONS

Starting the Engine

- 1 At the ground controls, turn the key switch to the desired position.
- 2 Be sure both ground and platform control red Emergency Stop buttons are pulled out to the on position.
- 3 Gasoline/LPG models: Choose fuel by moving the fuel select switch to the desired position.
- 4 Move the engine start toggle switch to either side. If the engine fails to start or dies, the restart delay will disable the start switch for 3 seconds.



If the engine fails to start after 15 seconds of cranking, determine the cause and repair any malfunction. Wait 60 seconds before trying to start again.

All models: In extreme cold conditions, 20°F / -6°C and below, warm the engine for 5 minutes to prevent hydraulic system damage.

Gasoline/LPG models: In extreme cold conditions, 20°F / -6°C and below, the machine should be started on gasoline, then switched to LPG.

Emergency Stop

Push in the red Emergency Stop button to the off position at the ground or platform controls to stop all machine functions and turn the engine off.

Repair any function that operates when the red Emergency Stop button is pushed in.

Selecting and operating the ground controls will override the platform red Emergency Stop button.

Auxiliary Controls

Use auxiliary power if the primary power source (engine) fails.

- 1 Turn the key switch to ground or platform control.
- 2 Pull out the red Emergency Stop button to the on position.
- 3 Press down the foot switch when operating the auxiliary controls from the platform.
- 4 Simultaneously hold the auxiliary power switch on and activate the desired function.



The drive function will not operate with auxiliary power.

Operation from Ground

- 1 Turn the key switch to ground control.
- 2 Pull out the red Emergency Stop button to the on position.
- 3 Gasoline/LPG models: Choose fuel by moving the fuel select switch to the desired position.
- 4 Start the engine.

To Position Platform

- 1 Hold the function enable switch to either side.
- 2 Move the appropriate toggle switch according to the markings on the control panel.



Drive and steer functions are not available from the ground controls.

OPERATING INSTRUCTIONS

Machines equipped with Platform Level Control Disable Function: The platform level toggle switch will not operate when the primary boom is raised past the drive speed limit switch.

Operation from Platform

- 1 Turn the key switch to platform control.
- 2 Pull out both ground and platform red Emergency Stop buttons to the on position.
- 3 Gasoline/LPG models: Choose fuel by moving the fuel select switch to the desired position.
- 4 Start the engine. Do not press down the foot switch when starting the engine.

To Position Platform

- 1 Press down the foot switch.
- 2 Slowly move the appropriate function control handle or toggle switch according to the markings on the control panel.

Machines equipped with Platform Level Control Disable Function: The platform level toggle switch will not operate when the primary boom is raised past the drive speed limit switch.

To Steer

- 1 Press down the foot switch.
- 2 Turn the steer wheels with the thumb rocker switch located on top of the drive control handle.

Use the color-coded direction triangles on the platform controls and the drive chassis to identify the direction the wheels will turn.

To Drive

- 1 Press down the foot switch.
- 2 Increase speed: Slowly move the drive control handle off center.
Decrease speed: Slowly move the drive control handle toward center.
Stop: Return the drive control handle to center or release the foot switch.

Use the color-coded direction arrows on the platform controls and the drive chassis to identify the direction the machine will travel.

Machine travel speed is restricted when the booms are raised or extended.

Drive Enable

Light on indicates that the boom has moved just past either non-steer wheel and the drive function has been interrupted.



To drive, hold the drive enable switch to either side and slowly move the drive control handle off center.

Be aware that the machine may move in the opposite direction that the drive and steer controls are moved.

Always use the color-coded direction arrows on the platform controls and the drive chassis to identify the direction the machine will travel.

Drive Speed Select



- Machine on incline symbol: Low range operation for inclines
- Machine on level surface symbol: High range operation for maximum drive speed

OPERATING INSTRUCTIONS

Engine Idle Select (rpm)

Select the engine idle (rpm) using the symbols on the control panel.



- Rabbit and foot switch symbol: foot switch activated high idle
- Turtle symbol: low idle
- Rabbit symbol: high idle

Generator (if equipped)

To operate the generator, move the generator toggle switch to the on position. The engine will continue to run but no drive or boom functions will operate.

Plug a power tool into the power to platform GFCI outlet.

To resume machine functions, move the generator toggle switch to the off position. All functions will operate.

Platform Overload Indicator Light (if equipped)

Light flashing indicates the platform is overloaded and no functions will operate.

Remove weight from the platform until the light goes off.

Machine Not Level Indicator Light (if equipped)

Light on indicates the machine is not level. The tilt alarm will be sounding when this light is on. Move the machine to a firm level surface.

Fall Protection

Personal fall protection equipment (PFPE) is required when operating this machine.

All PFPE must comply with applicable governmental regulations, and must be inspected and used in accordance with the PFPE manufacturer's instructions.

After Each Use

- 1 Select a safe parking location—firm level surface, clear of obstruction and traffic.
- 2 Retract and lower the boom to the stowed position.
- 3 Rotate the turntable so that the boom is between the non-steer wheels.
- 4 Turn the key switch to the off position and remove the key to secure from unauthorized use.
- 5 Chock the wheels.

Decals

Inspection for Decals with Words

Determine whether the decals on your machine have words or symbols. Use the appropriate inspection to verify that all decals are legible and in place.

Part No.	Decal Description	Quantity
27564	Danger - Electrocutation Hazard	2
28158	Label - Unleaded	1
28159	Label - Diesel	1
28160	Label - LPG	1
28161	Danger - Crushing Hazard	3
28164	Notice - Hazardous Materials	1
28165	Notice - Foot Switch	1
28171	Label - No Smoking	2
28174	Label - Power to Platform, 230V	2
28175	Caution - Compartment Access	1
28176	Notice - Missing Manuals	1
28177	Warning - Platform Rotate	2
28181	Warning - No Step or Ride	1
28235	Label - Power to Platform, 115V	2
28236	Warning - Failure To Read . . .	1
31060	Danger - Tip-over Hazard, Interlock	4
32700	Danger - Safety Rules	2
33952	Danger - Tilt-Alarm	1
37051	Notice - Max Side Force, 150 lbs / 667 N	1
37052	Notice - Maximum Load, 500 lbs / 227 kg	1
37053	Arrow - Blue	1
37054	Arrow - Yellow	1
37055	Triangle- Blue	2
37056	Triangle - Yellow	2

Part No.	Decal Description	Quantity
40434	Label - Lanyard Anchorage	2
41971	Notice - Tire Pressure	4
43595	Danger - Tip Over Hazard, Do Not Use Air Filled Tires (Australia only)	4
43613	Notice - Kubota WG-750/DF-750 Engine Specs	1
43614	Notice - Kubota D905 B-22 Engine Specs	1
44981	Label - Air Line to Platform	2
44986	Notice - Max Manual Force, 90 lbs / 400 N	1
43647	Notice - Operating Instructions	2
44779	Notice - Generator (option)	1
52968	Cosmetic - Genie Boom	1
62930	Cosmetic - Genie Z-34/22	1
62947	Cosmetic - IC Power 4 x 2	1
62948	Cosmetic - IC Power 4 x 4	1
72094	Ground Control Panel	1
72095	Platform Control Panel	1
82366	Label - Chevron Rykon	1
133299	Label - Wheel Load	4

DECALS

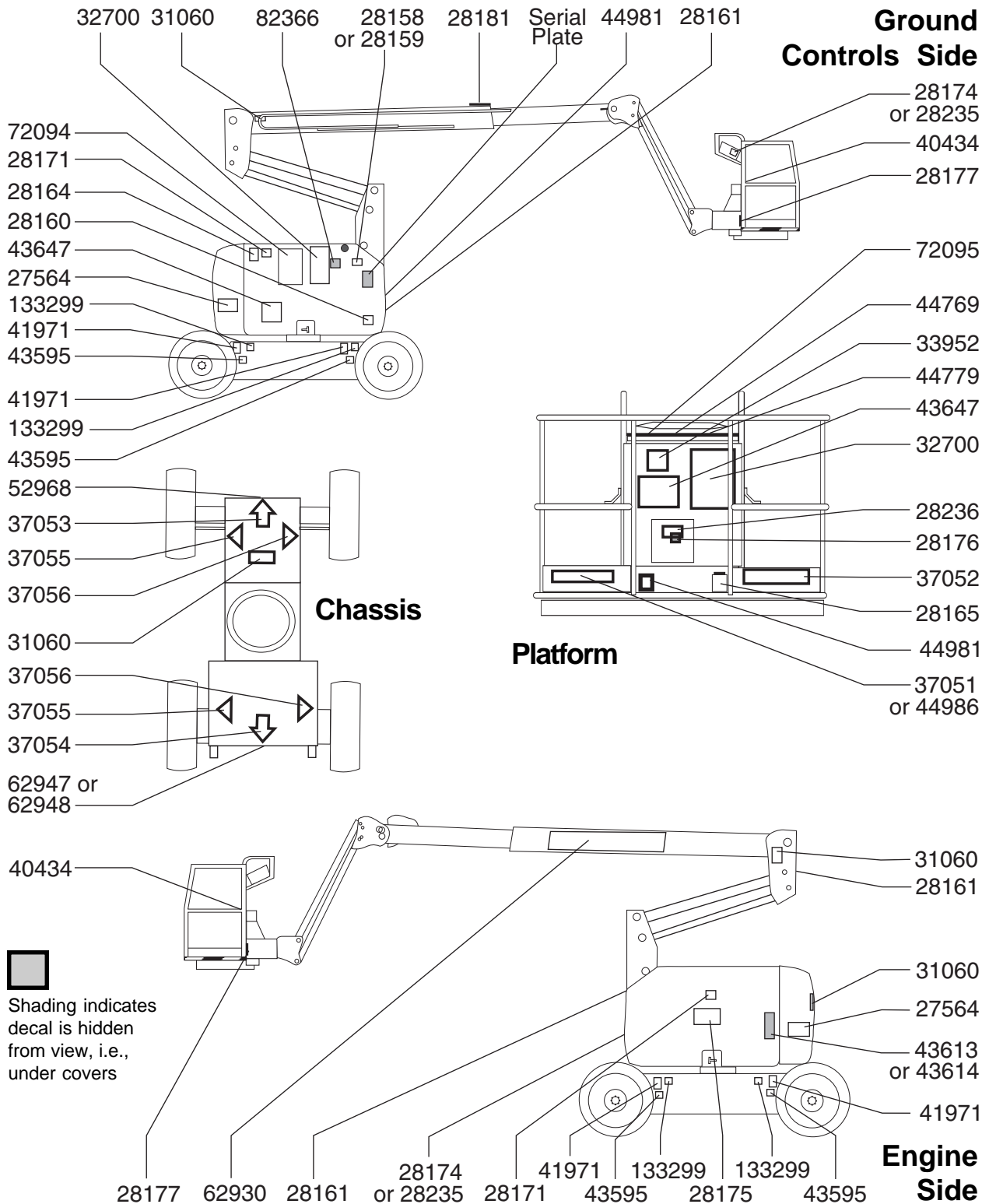

DECALS

Inspection for Decals with Symbols

Determine whether the decals on your machine have words or symbols. Use the appropriate inspection to verify that all decals are legible and in place.

Part No.	Decal Description	Quantity
28158	Label - Unleaded	1
28159	Label - Diesel	1
28160	Label - LPG	1
28171	Label - No Smoking	2
28174	Label - Power to Platform, 230V	2
28235	Label - Power to Platform, 115V	2
37053	Arrow - Blue	1
37054	Arrow - Yellow	1
37055	Triangle- Blue	2
37056	Triangle - Yellow	2
40434	Label - Lanyard Anchorage	2
44981	Label - Air Line to Platform	2
44779	Label - Generator (option)	1
52968	Cosmetic - Genie Boom	1
62930	Cosmetic - Genie Z-34/22	1
62947	Cosmetic - IC Power 4 x 2	1
62948	Cosmetic - IC Power 4 x 4	1

Part No.	Decal Description	Quantity
72094	Ground Control Panel	1
72095	Platform Control Panel	1
82472	Warning - Crushing Hazard	3
82473	Caution - Compartment Access	1
82487	Label - Operating Instructions	2
82544	Danger - Electrocution Hazard	2
82548	Warning - Platform Rotate	2
82601	Danger - Maximum Load, 227 kg	1
82602	Danger - Max Manual Force, 667 N	1
82604	Danger - Max Manual Force, 400 N	1
82611	Label - Drive Enable Patch	1
133299	Label - Wheel Load	4

DECALS

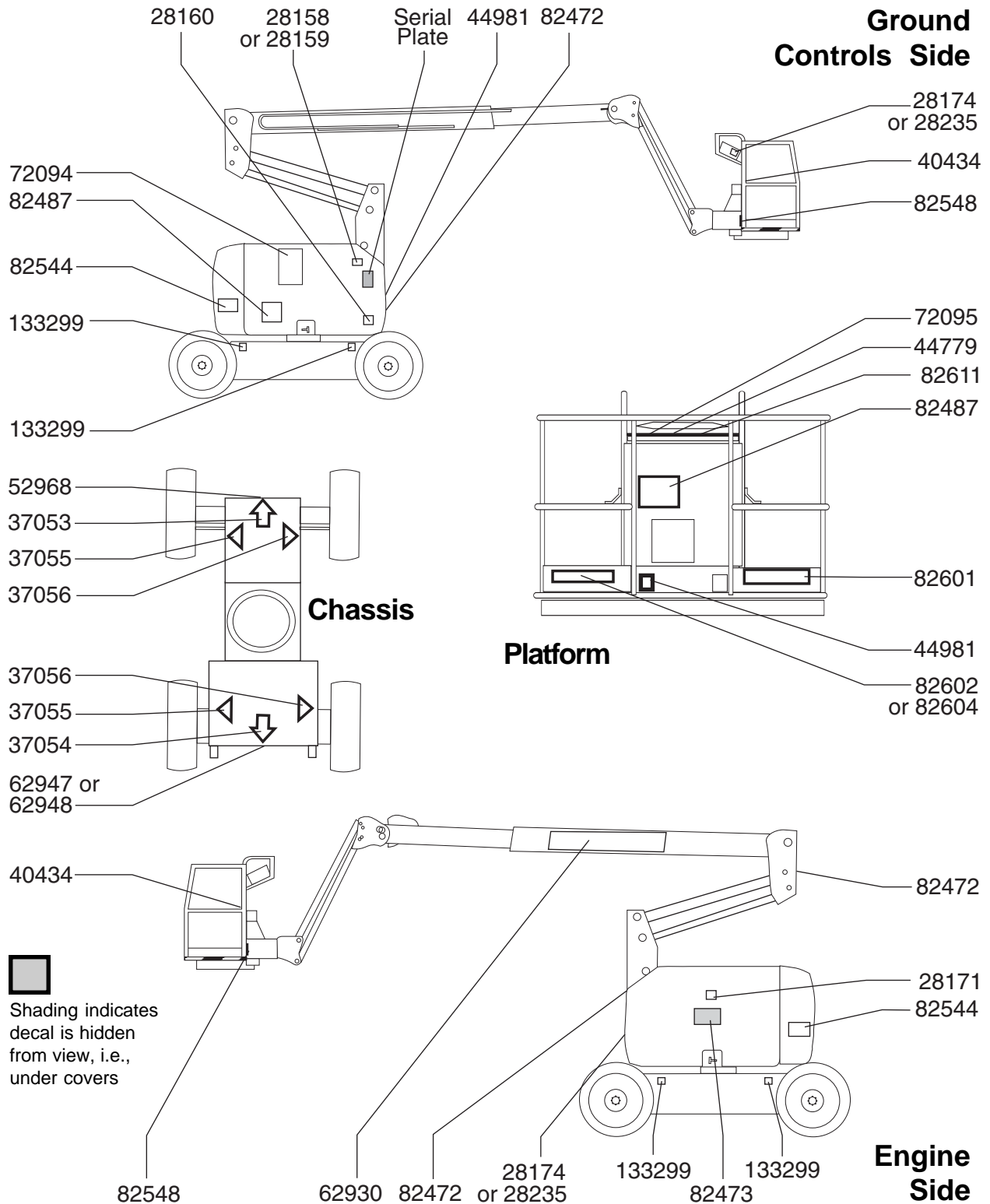

Transport and Lifting Instructions



Observe and Obey:

- ☑ The transport vehicle must be parked on a level surface.
- ☑ The transport vehicle must be secured to prevent rolling while the machine is being loaded.
- ☑ Be sure the vehicle capacity, loading surfaces and chains or straps are sufficient to withstand the machine weight. See the serial plate for the machine weight.
- ☑ The machine must be on a level surface or secured before releasing the brakes.

Free-wheel Configuration for Winching

- 1 Chock the wheels to prevent the machine from rolling.
- 2 Release the non-steer wheel brakes by turning over the torque hub disconnect caps (see below).
- 3 Be sure the winch line is properly secured to the drive chassis tie points and the path is clear of all obstructions.

After the machine is loaded:

- 1 Chock the wheels to prevent the machine from rolling.
- 2 Apply the non-steer wheel brakes by turning over the torque hub disconnect caps (see below).

Towing a Genie Z-34/22 is not recommended. If the machine must be towed, do not exceed 2 mph / 3.2 km/h.

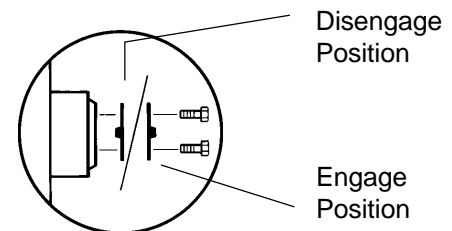

TRANSPORT AND LIFTING INSTRUCTIONS

Securing to Truck or Trailer for Transit

Always chock the machine wheels in preparation for transport.

Turn the key switch to the off position and remove the key before transporting.

Inspect the entire machine for loose or unsecured items.

Securing the Chassis

Use the tie points on the drive chassis for anchoring down to the transport surface.

Use chains or straps of ample load capacity.

Use a minimum of 4 chains.

Adjust the rigging to prevent damage to the chains.

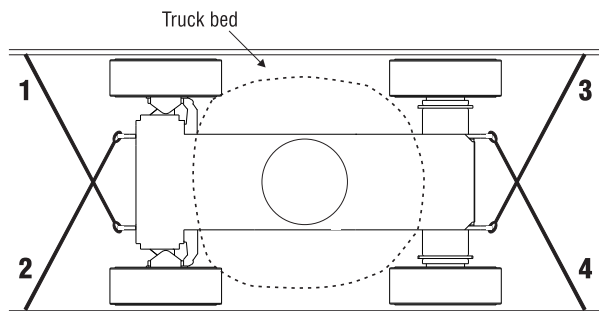

Securing the Platform

Make sure the jib and platform are in the stowed position.

Place a block under the edge of the platform beneath the platform entry.

Secure the platform with a nylon strap placed over the platform mount near the platform rotator (see below). Do not use excessive downward force when securing the boom section.

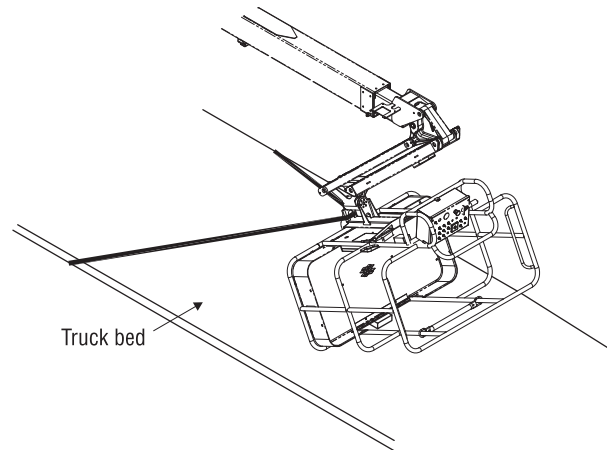

TRANSPORT AND LIFTING INSTRUCTIONS



Observe and Obey:

- Only qualified riggers should rig and lift the machine.
- Be sure the crane capacity, loading surfaces and straps or lines are sufficient to withstand the machine weight. See the serial plate for the machine weight.

Lifting Instructions

Fully lower and retract the boom. Fully lower the jib. Remove all loose items on the machine.

Determine the center of gravity of your machine using the table and the picture on this page.

Attach the rigging only to the designated lifting points on the machine. There are four lifting points on the chassis.

Adjust the rigging to prevent damage to the machine and to keep the machine level.

X Axis	35.9 in	91.3 cm
Y Axis	33.3 in	84.7 cm

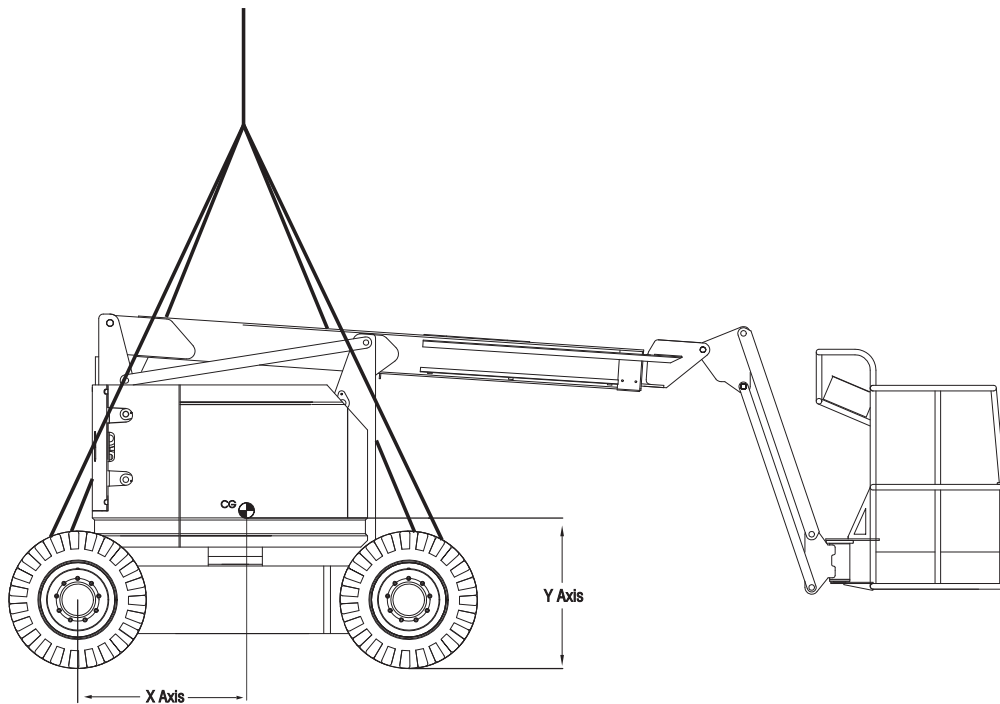

Specifications

Height, working maximum	40 ft 8 in	12.4 m
Height, platform maximum	34 ft 8 in	10.6 m
Height, stowed maximum	6 ft 7 in	2 m
Horizontal reach maximum	22 ft 4 in	6.8 m
Width	5 ft 8 in	1.7 m
Length, stowed	18 ft 6 in	5.6 m
Maximum load capacity	500 lb	227 kg
Wheelbase	6 ft 2 in	1.9 m
Turning radius (outside)	13 ft 1 in	4 m
Turning radius (inside)	5 ft 8 in	1.7 m
Ground clearance		
2WD models	5.75 in	14.6 cm
4WD models	6.5 in	16.5 cm
Turntable rotation (degrees)		355°
Turntable tailswing		0
Platform leveling		self-leveling
Platform rotation (degrees)		180°
Controls		12V DC proportional
Platform dimensions, (length x width)	56 in x 30 in 1.4 m x 76 cm	
Power source	Kubota G/LPG 24.5 hp OR Kubota Diesel 26 hp	
Fuel capacity	11.5 gallons	43.5 liters
Gradeability (boom stowed)		
2WD models		37%
4WD models		45%
AC outlet in platform		standard
Hydraulic pressure, maximum (boom functions)	3200 psi	220.7 bar
System voltage		12V

Tires size (ANSI)	
Industrial	9-14.5
Rough terrain	10-16.5NHS

Tires size (CE and Australia)	
Foam filled only	9-14.5

Weight	See Serial Plate
(Machine weights vary with option configurations)	

Airborne noise emissions	80 dB
Maximum sound level at normal operating workstations (A-weighted)	

Drive speeds, maximum,

Boom stowed			
2WD models	4.5 mph	7.2 km/h	
	40 ft/6.1 sec	12.2 m/6.1 sec	
4WD models	4.0 mph	6.4 km/h	
	40 ft/6.8 sec	12.2/6.8 sec	

Boom		
raised or extended	0.6 mph	1.0 km/h
2WD & 4WD models	40 ft/40 sec	12.2 m/40 sec

Floor Loading Information

GVW+Rated Load	11,000 lbs	4989 kg
Axle load, maximum	8300 lbs	3764 kg
Wheel load, maximum	5300 lbs	2404 kg
Localized pressure per tire	100 psi	7.03 kg/cm ² 690 kPa
Occupied floor pressure	221 psf	10.58 kPa

Note: Floor loading information is approximate and does not incorporate different option configurations. It should be used only with adequate safety factors.

Continuous improvement of our products is a Genie policy. Product specifications are subject to change without notice or obligation.

Range of Motion

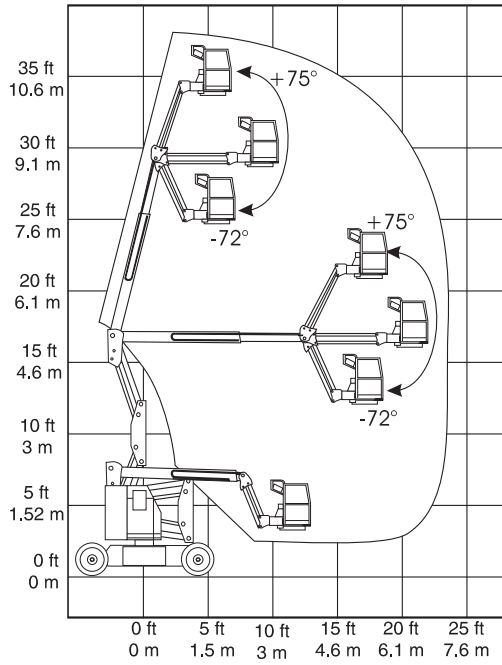

California Proposition 65

WARNING

The exhaust from this product contains chemicals known to the State of California to cause cancer, birth defects or other reproductive harm.

Genie Scandinavia
Phone +46 31 575100
Fax +46 31 579020

Genie France
Phone +33 (0)2 37 26 09 99
Fax +33 (0)2 37 26 09 98

Genie Iberica
Phone +34 93 579 5042
Fax +34 93 579 5059

Genie Germany
Phone 0800 180 9017
Phone +49 422 149 1818
Fax +49 422 149 1820

Genie U.K.
Phone +44 (0)1476 584333
Fax +44 (0)1476 584334

Genie Mexico City
Phone +52 55 5666 5242
Fax +52 55 5666 3241

Genie North America
Phone 425.881.1800
Toll Free USA and Canada
800.536.1800
Fax 425.883.3475

Genie Australia Pty Ltd.
Phone +61 7 3375 1660
Fax +61 7 3375 1002

Genie China
Phone +86 21 53852570
Fax +86 21 53852569

Genie Malaysia
Phone +65 98 480 775
Fax +65 67 533 544

Genie Japan
Phone +81 3 3453 6082
Fax +81 3 3453 6083

Genie Korea
Phone +82 25 587 267
Fax +82 25 583 910

Genie Brasil
Phone +55 11 41 665 755
Fax +55 11 41 665 754

Genie Holland
Phone +31 183 581 102
Fax +31 183 581 566

Distributed By: